

400

for light commercial and industrial swing-leaf gates



■ A wide range of models

The FAAC 400 offers a range of 7 different operators, with or without hydraulic locking designed to automate swing gates up to 7 metres per leaf. The whole range is easily installed and models are available for very heavy gates, industrial gates and high frequency operators.

■ Safe both inside and out

The exclusive hydraulic device, ensuring maximum anti-crushing protection, features two highly sensitive by-pass valves. In case of an emergency, a customised release key makes it possible to operate the gate manually. The power of hydraulic locking gives the system exceptionally high resistance against break-in attempts.

■ FAAC's experience is a guarantee

The motor unit is contained in a compact hydraulic enbloc housing; all components are oil-bath lubricated and continuously cooled, require very little maintenance, and are low on electrical power consumption.

■ Reliability and low noise

Precision mechanics and use of hydraulic oil as motor fluid are the secrets behind the extremely low noise movement. Reliability is assured under any atmospheric conditions and at extreme temperatures in the range -40° C to +55° C.

ACE DOORS INC.

Mark Pelkey ext:111

<http://www.acedoors.ca>



705-322-0363

1800-561-0656

ext111@acedoors.ca



- 1 Rod protective housing
- 2 Key-operated emergency release
- 3 Oil tank

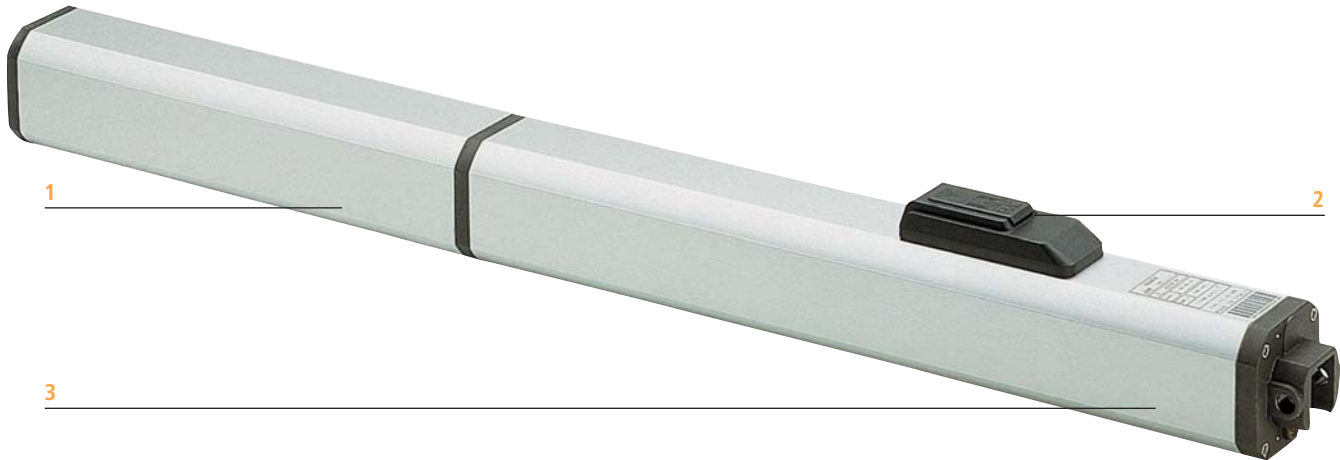

DIMENSIONS

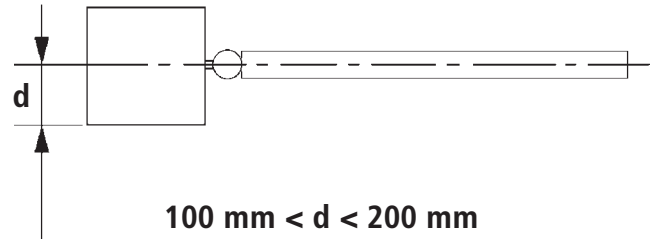
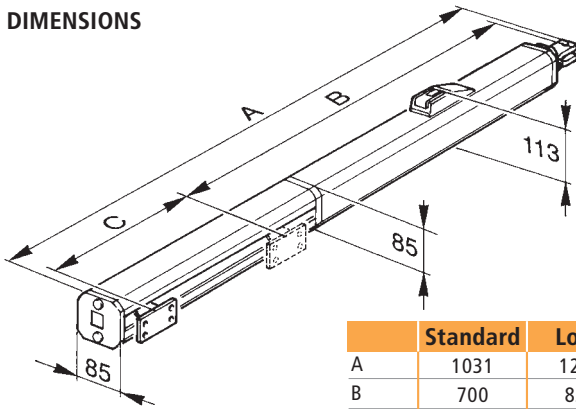

	Standard	Long
A	1031	1285
B	700	822
C	260	380

Values in mm

Technical specifications	400 CBC	400 CBAC	400 SB	400 SBS	400 CBACR	400 CBAC LN	400 SB LN
Power supply	115 Vac (+6% -10%) 50 (60) Hz						
Absorbed power	220 W						
Absorbed current	1 A						
Motor rotation speed	1400 rpm						
Rod extension speed	1 cm/s		0,75 cm/s		1,5 cm/s		
Pump flow rate	1 l/min		0,75 l/min		1,5 l/min		
Traction and thrust force	0÷620 daN		0÷775 daN		0÷465 daN		
Operating ambient temperature	-40°C ÷ +55°C						
Thermal protection on motor winding	120°C						
Weight	8,6 kg						
Type of oil	FAAC HP OIL						
Protection class	IP 55						

Model	Use		
	Single leaf max length (m)	No. of leaves	Use frequency (cycles/hour)
400 CBC	2,20	1	70
400 SB	4,00	1	70
400 SBS	7,00	1	60
400 CBAC	2,20	1	70
400 CBACR	2,20	1	80
400 CBAC long	2,20	1	50
400 SB long	2,50	1	50