

FAAC

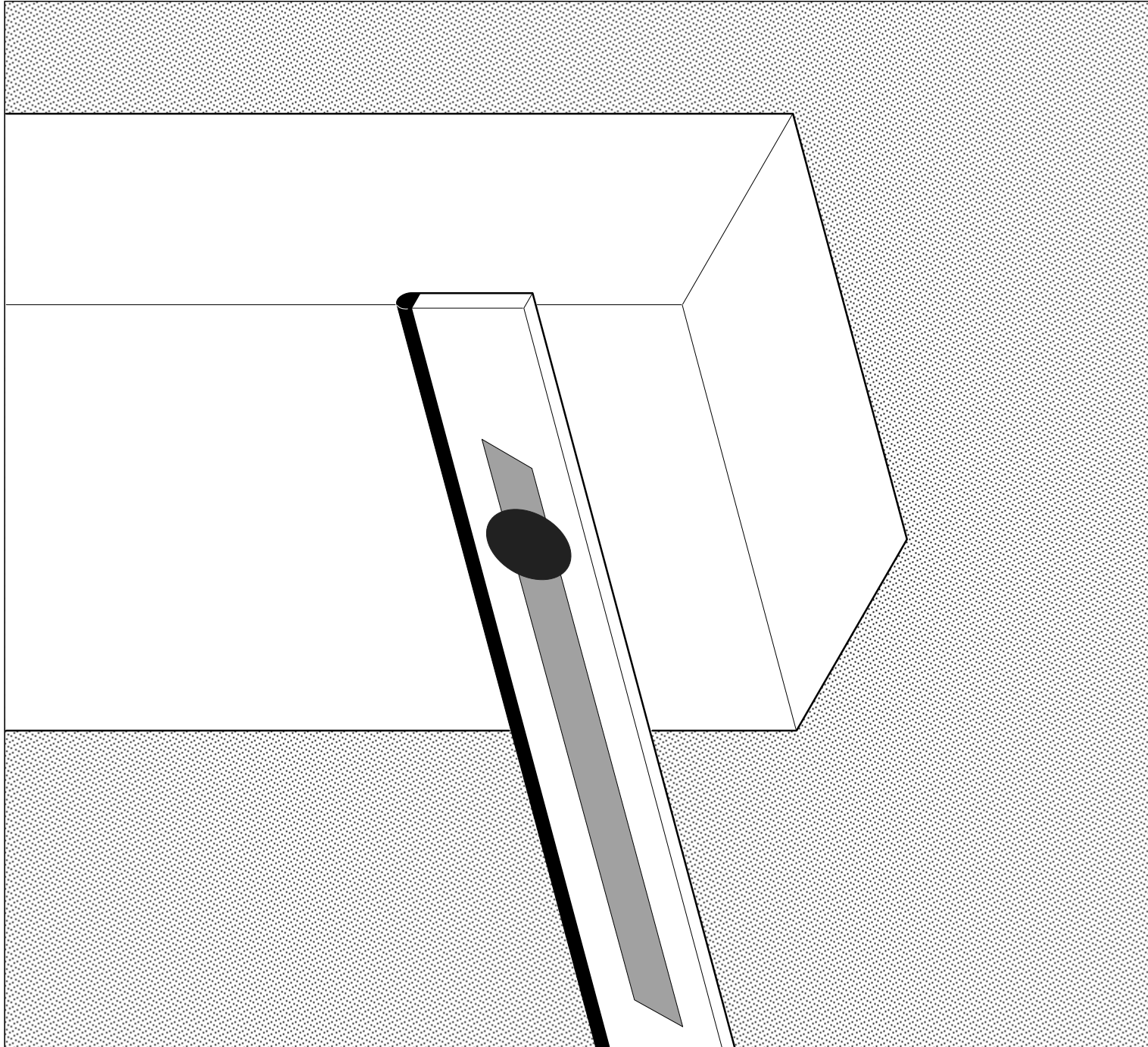

630

EC MACHINE DIRECTIVE COMPLIANCE DECLARATION

(DIRECTIVE 89/392 EEC, APPENDIX II, PART B)

Manufacturer: FAAC S.p.A.**Address:** Via Benini, 1
40069 - Zola Predosa
BOLOGNA - ITALY**Hereby declares that:** the 630 automation system

- is intended to be incorporated into machinery, or to be assembled with other machinery to constitute machinery in compliance with the requirements of Directive 89/392 EEC, and subsequent amendments 91/368 EEC, 93/44 EEC and 93/68 EEC;
- complies with the essential safety requirements in the following EEC Directives:

73/23 EEC and subsequent amendment 93/68 EEC.
89/336 EEC and subsequent amendments 92/31 EEC and 93/68 EEC.

and furthermore declares that unit must not be put into service until the machinery into which it is incorporated or of which it is a component has been identified and declared to be in conformity with the provisions of Directive 89/392 EEC and subsequent amendments enacted by the national implementing legislation.

Bologna, 1 January 1997

Managing
Director

A. Bass

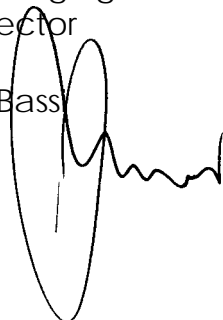
A handwritten signature in black ink, appearing to be 'A. Bass', written over the printed name. The signature is stylized with a large loop and a wavy tail.

IMPORTANT NOTICE FOR THE INSTALLER

GENERAL SAFETY REGULATIONS

- 1) **WARNING! FAAC strongly recommends to follow these instructions literally for the safety of persons. Improper installation or misuse of the product will cause very serious damages to persons.**
- 2) Packaging material (plastic, polystyrene etc.) is a potential hazard and must be kept out of reach of children.
- 3) Read the instructions carefully before installing the product.
- 4) Keep these instructions for future reference.
- 5) This product has been designed and manufactured only for the use stated in this manual. Any other use not expressly set forth will affect the reliability of the product and/or could be source of hazard.
- 6) FAAC S.p.A. cannot be held responsible for any damage caused by improper use or different from the use for which the automation system is destined to.
- 7) Do not use this device in areas subject to explosion: the presence of flammable gas or fumes is a serious hazard.
- 8) Mechanical constructive elements must comply with UNI8612, CEN pr EN 12604 and CEN pr EN 12605 standards.
Countries outside the EC shall follow the regulations above besides their national normative references in order to offer the utmost safety.
- 9) FAAC cannot be held responsible for failure to observe technical standards in the construction of gates and doors, or for any deformation of the gates which may occur during use.
- 10) Installation must comply with UNI8612, CEN pr EN 12453 and CEN pr EN 12635.
The degree of safety of the automation must be C+E.
- 11) Before carrying out any operations, turn off the system's main switch.
- 12) An omnipower switch shall be provided for the installation with an opening distance of the contacts of 3 mm or more. Alternatively, use a 6A thermomagnetic breaker with multi-pole switching.
- 13) Ensure that there is a differential switch up-line of the electrical system, with a trip threshold of 0.03A.
- 14) Check that the earthing plant is in perfect condition and connect it to the metallic parts. Also earth the yellow/green wire of the operator.
- 15) The automation is fitted with an anti-crush safety system that is a torque control device. In any case, further safety devices shall be installed.
- 16) The safety devices (e.g. photocells, safety edges, etc.) protect areas wherethere is a mechanical movement hazard, e.g. crushing, entrapment and cutting.
- 17) Each installation must be fitted with at least one flashing light (e.g. FAAC LAMP, MINILAMP etc.) as well as a warning plate suitably fixed to the gate, besides the safety devices as per point 16. above.
- 18) FAAC cannot be held responsible regarding safety and correct functioning of the automation in the event that parts other than FAAC original parts are used.
- 19) Use only FAAC original spare parts for maintenance operations.
- 20) Do not carry out any modifications to automation components.
- 21) The installer must supply all information regarding manual operation of the system in the event of an emergency and provide the end-user with the leaflet attached to the product.
- 22) Keep out of persons when the product is in operation.
- 23) Keep out of reach of children the remote radio controls and any control devices. The automation could be operated unintentionally.
- 24) The end-user must avoid any attempt to repair or adjust the automation personally. These operations must be carried out exclusively by qualified personnel.
- 25) **What is not explicitly stated in these instructions is not permitted.**

THE 630 AUTOMATION SYSTEM

The 630 system consists of a white aluminium beam fitted with reflectors and a cathaphoresis-treated steel housing with a polyester finish that holds the hydraulic operator and is also designed to hold the electronic control unit. The beam is raised and lowered by the operator which is a single hydraulic unit consisting of an electric pump and a piston/rack group.

The system has an adjustable anti-crushing safety system, a device that stops and locks the beam in any position, and a convenient manual release device to be used in the event of a power failure or malfunction.

The beam balance spring and the electronic control unit (not provided) must be ordered with reference to the price list.

The 630 system has been designed and constructed for vehicle access control. It must not be used for any other purpose.

1. DESCRIPTION AND TECHNICAL CHARACTERISTICS

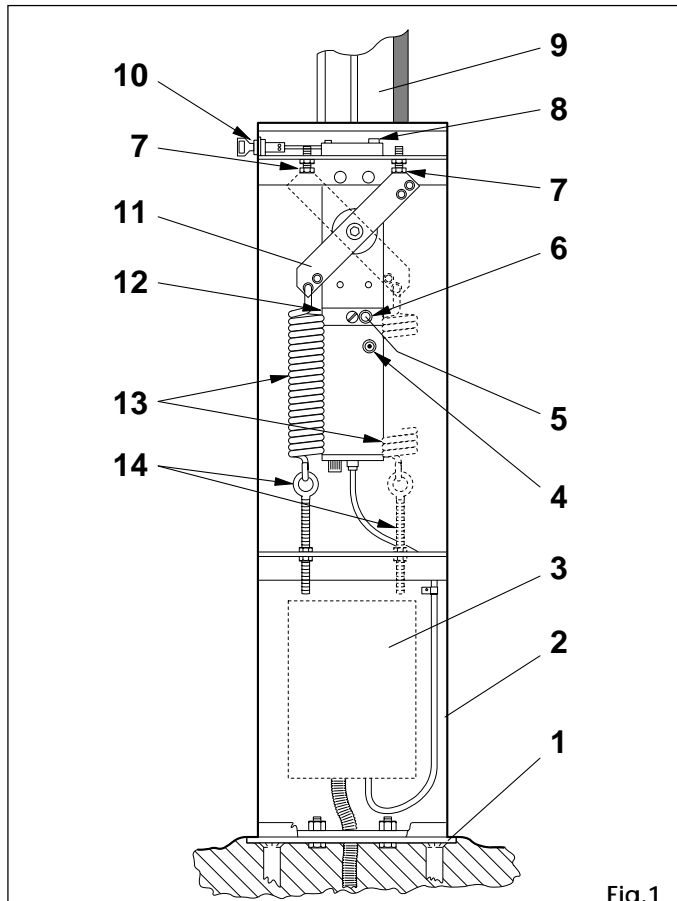

Fig.1

- | | |
|--|-----------------------------|
| ① base plate | ⑦ end stop screw |
| ② barrier housing | ⑧ upper breather screw |
| ③ electronic control unit (not provided) | ⑨ beam |
| ④ oil level inspection window | ⑩ emergency release key |
| ⑤ central breather screw | ⑪ pivot arm |
| ⑥ oil filler cap | ⑫ torque setting screws |
| | ⑬ balance spring |
| | ⑭ spring adjustment tie-rod |

Table 1 Technical characteristics of the 630 automation system

BARRIER MODEL	630/25	630/35	630/40
Max. beam length (m)	2.5	3.5	4
Maximum open time (s)	3	5	8
Angular velocity (rpm)	5	3	2
Pump flow rate (l/min.)	3	1.5	1
Max torque(Nm)	110	230	320
Type of beam	Rigid/With Skirt/Articulated		
Duty cycle	50%		
Power supply	230V~ (+6 -10 %) 50Hz		
Absorbed power (W)	220		
Oil type	FAAC XD 220		
Oil quantity (l)	1.2		
Motor winding thermal cutout	120° C		
Anti-crushing system	bypass valve fitted as std.		
Temperature range	-20 ÷ +55 °C		
Casing protective treatment	cathaphoresis		
Casing finish	polyester paint, RAL 2004		
Housing protection	IP 55		
Weight (kg)	43		
Housing dimensions LxHxP(mm)	270 x 990 x 171.5		
Technical characteristics of electric motor			
Speed (rpm)	2800	1400	
Power (W)	200	200	
Current drawn (A)	1	1.2	
Power supply	230V~ (+6 -10 %) 50Hz		

1.1. MAXIMUM DUTY CYCLE CURVE

The curve allows the maximum working time (T) to be obtained as a function of duty cycle (F).

For example, the 630 operators can operate uninterruptedly at a duty cycle of 50%.

To ensure good operation, keep to the field of operation lying below the curve.

Important: The curve refers to a temperature of 24°C. Exposure to direct sunlight can result in a reduction in duty cycle to as low as 20%.

Calculating duty cycle

The duty cycle is the percentage of effective working time (opening + closing) with respect to the total cycle time (opening + closing + pause times).

It is calculated using the following formula:

$$\%F = \frac{Ta + Tc}{Ta + Tc + Tp + Ti} \times 100$$

where:

Ta = opening time

Tc = closing time

Tp = pause time

Ti = interval between one complete cycle and the next.

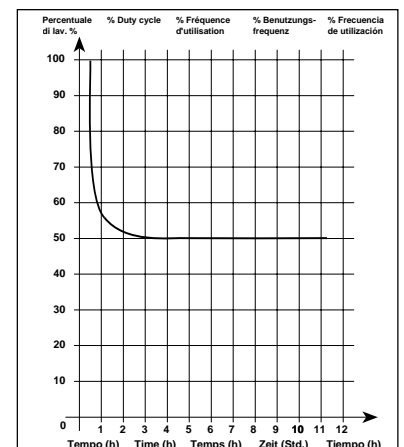

2. STANDARD INSTALLATION LAYOUT

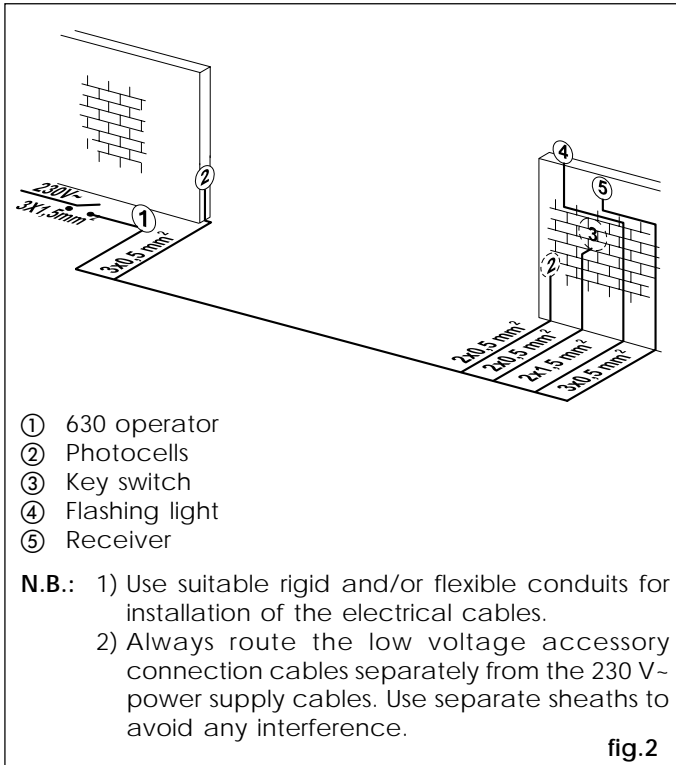

3. DIMENSIONS

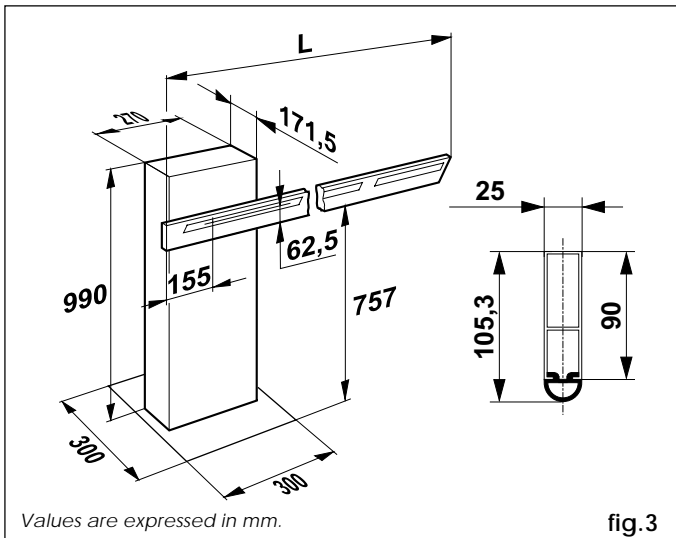

4. INSTALLING THE SYSTEM

4.1. PRELIMINARY CHECKS

For safe, correct operation of the automation system, make sure that the following requirements are met:

- During its movement the beam does not strike against obstacles or overhead power cables.
- The characteristics of the ground must ensure sufficient support for the foundation plinth.
- There must be no pipes or electrical cables in the area to be dug for installing the foundation plinth.
- If the housing is located in a vehicle transit area, it is a good idea to provide protection against accidental collisions.
- Check that the housing is provided with an efficient earth connection.

4.2. INSTALLING THE BASE PLATE

- 1) Prepare a foundation plinth as shown in fig. 4 (for soft ground).
- 2) Install the base plate as shown in fig. 4, providing one or more conduits for electrical cables. Use a level to check that the plate is perfectly horizontal and wait for the cement to set.

4.3. MECHANICAL INSTALLATION

- 1) Fix the housing to the base plate using the four nuts provided, as shown in fig. 5. The housing should normally be installed with the door on the premises side.
- 2) Set up the operator for manual operation as described in section 6.
- 3) **Remove the two breather screws as shown in fig. 6 and keep them in a safe place.**
- 4) Determine whether installation is right-handed (Fig. 7/A) or left-handed (Fig. 7/B) for subsequent reference.
- 5) Insert the splined shaft (1, fig. 7) into the seat in the operator; turn it manually as far as it will go in the opening direction, then turn it back in the opposite direction by about 10°.
- 6) Fit the pivot arm (2, fig. 7) onto the splined shaft, tilting it by 45° as shown in fig. 7.
- 7) Fit the flange (3, fig. 7) onto the beam (4, fig. 7) using the screws provided.
- 8) Keeping the beam vertical, fit it onto the part of the splined shaft that protrudes outside the housing. The rubber strip on the bar must be on the closure side.
- 9) Fasten the beam to the shaft by inserting the screw, the washer and the centring bushing (5, fig. 7).
- 10) Fit the cap over the hole (6, fig. 7).
- 11) Tighten up the screws that secure the pivot arm and the beam to the shaft.
- 12) Fit and adjust the balance spring.

4.4. FITTING AND ADJUSTING THE BALANCE SPRING

- 1) Check that the balance spring is suitable for the type of beam installed: see section 8.
- 2) Check that the operator is unlocked: see section 6.
- 3) Keeping the beam in a vertical position, fit the tie-rod (7, fig. 7) in such a way as to allow the spring (8, fig. 7) to be connected to the pivot arm and the tie-rod.
- 4) Position the bar at 45° and adjust the tie-rod so that the spring balances the weight of the bar in this position.
- 5) Tighten up the two nuts that secure the tie-rod to the housing.
- 6) Return to normal operation as described in section 7.

5. START-UP

5.1. CONNECTING ELECTRONIC CONTROL UNIT

The electronic control unit must be ordered separately. Install the electronic control unit following the instructions provided.

5.2. ADJUSTING TRANSMITTED TORQUE

Use the two by-pass screws (fig. 8) to regulate the hydraulic transmitted torque adjustment system.

The red screw adjusts torque during closure.

The green screw adjusts torque during opening.

Turn the screws clockwise to increase torque.

Turn the screws anticlockwise to reduce torque.

5.3. ADJUSTING END STOP SCREWS

Adjust the position of the beam in the maximum opening and closing positions by setting the end stop screws as shown in fig. 9.

5.4 TESTING BARRIER UNIT

Once installation is complete, affix the danger warning adhesive on the top of the housing (fig. 10).

Carry out a thorough functional check of the barrier unit and all accessories connected to it. Give the page entitled "End-user guide" to the customer and demonstrate how to operate the barrier correctly, drawing the customer's attention to the points of potential danger.

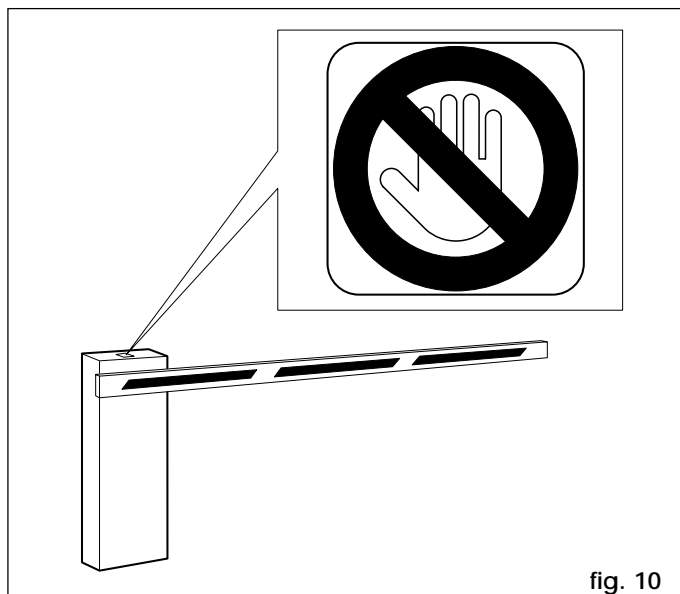

fig. 10

6. MANUAL OPERATION

If the barrier needs to be operated manually as a result of a power failure or malfunction, use the unlock device as follows.

The key provided can be triangular (standard) or personalised (optional).

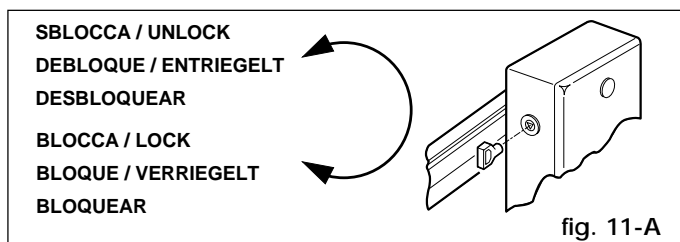

fig. 11-A

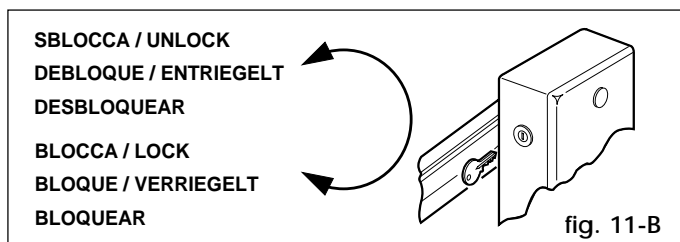

fig. 11-B

- Insert the standard key (fig. 11-A) or the personalised key (fig. 11-B) in the lock and **turn anticlockwise** by one revolution.
- Open or close the barrier manually.

7. RETURNING TO NORMAL OPERATION

To prevent an accidental impulse from activating the barrier, turn off the system's electrical power supply before returning to normal operation.

triangular key (standard):

- turn the key **clockwise** until it stops, then remove it.

personalised key (optional):

- turn the key **clockwise** until it stops.
- turn the key **anticlockwise** very slowly to the point where it can be removed.

8. BALANCE SPRINGS

The 630 barrier unit requires a beam balance spring which must be ordered separately. The spring varies according to the length and type of beam (rigid, with skirt or articulated).

Refer to the tables below to determine the type of spring required.

8.1. SPRINGS FOR RIGID BEAMS AND BEAMS WITH SKIRTS

Table 2

BALANCE SPRING			
Ø	rigid beam	beam with skirt	code
5.5	up to 2.5 m	up to 2.5 m	721008
6		2 ÷ 2.5 m	721005
6.5	2.5 ÷ 3 m	2.5 ÷ 3 m	721013
7	3 ÷ 4 m		721006
7.5		3 ÷ 4 m	721007

8.2. SPRINGS FOR ARTICULATED BEAMS

Table 3

Balance spring table		
L (mm)	A (mm)	code
Up to 2000	1000 ÷ 1500	721008
	1500 ÷ 2000	721005
2000 ÷ 3000	1000 ÷ 1500	721008
	1500 ÷ 2000	721005
	2000 ÷ 2250	721013
3000 ÷ 4000	1000 ÷ 2000	721013
	2000 ÷ 2250	721006

A	= H - 780 mm
B	= L - A
A MAX	= 2250 mm

9. ACCESSORIES

SKIRT KIT

The skirt kit serves to increase barrier visibility. It is available in lengths 2 m and 3 m.

IMPORTANT: If a skirt is fitted the balance spring will have to be adapted.

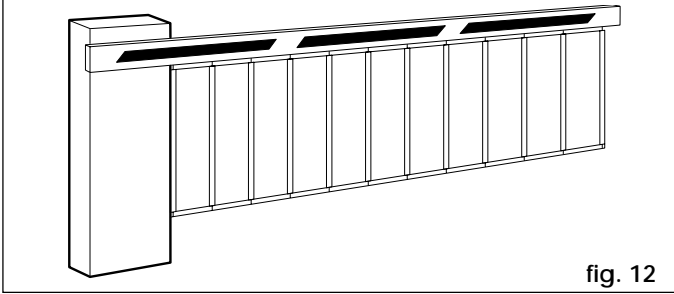

fig. 12

ARTICULATION KIT

The articulation kit allows the rigid beam to be articulated to a maximum ceiling height of 3 metres.

IMPORTANT: If the articulation kit is fitted the balance spring will have to be adapted.

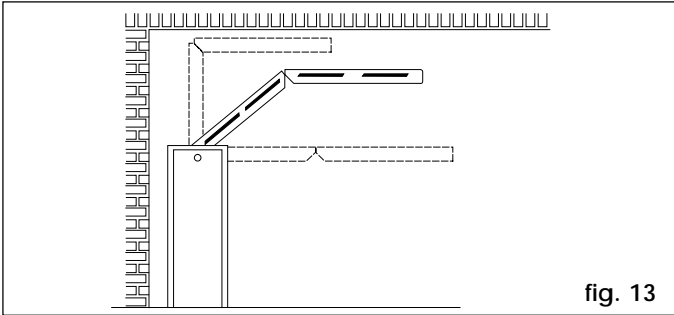

fig. 13

SUPPORT FORK

The support fork performs two functions:

- It prevents the beam from bending or breaking if excessive force is applied at its end.
- It acts as a rest for the beam in the closed position and prevents the beam from flexing downwards.

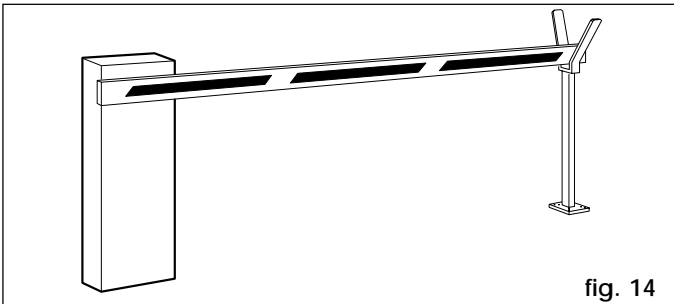

fig. 14

POSITIONING OF SUPPORT FORK BASE PLATE

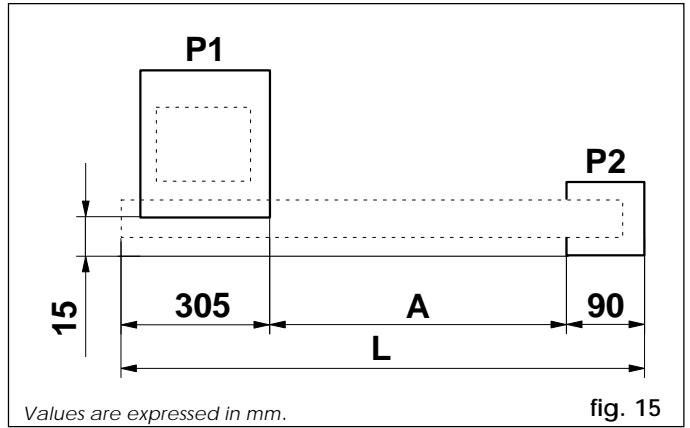

fig. 15

To position the support fork base plate, refer to fig. 15, where:

- P1 = barrier base plate
- P2 = support fork base plate
- L = beam length (in mm)
- A = L - 395 (in mm)

10. MAINTENANCE

When performing maintenance always check that the bypass screws are set correctly, that the system is balanced and that the safety devices operate correctly.

10.1. TOPPING UP WITH OIL

Check periodically the quantity of oil inside the tank. For medium/low duty cycles a yearly check is sufficient; for more severe operation it is advisable to check every 6 months.

The level must not fall below the level mark on the inspection window (4, fig. 1).

To top up, unscrew the filler cap (6, fig. 1) and pour in oil up to the correct level.

Use exclusively FAAC XD 220 oil.

10.2. BLEEDING AIR FROM HYDRAULIC CIRCUIT

If the beam moves in an irregular manner, this may be due to the presence of air in the hydraulic circuit.

If it is necessary to bleed the air, proceed as follows:

- 1) Check that the breather screws have been removed (fig. 6).
- 2) Disassemble the beam and the spring / pivot arm unit from the splined shaft.
- 3) Set an operating time of about 1 minute on the electronic control unit.
- 4) Activate the operator electrically so that it turns to the end of its travel in both directions of rotation.
- 5) Repeat this operation several times if necessary.
- 6) Follow the installation instructions to reassemble.

11. REPAIRS

For repairs, contact an authorised FAAC Service Centre.

END-USER GUIDE

THE 630 AUTOMATION SYSTEM

Read the end user guide carefully before using the product and keep it in a safe place for future reference.

GENERAL SAFETY INSTRUCTIONS

If correctly installed and operated, the 630 automation system ensures a high level of safety.

However, some simple rules should be followed to avoid accidents:

- Do not transit underneath the beam while it is moving. Wait until it is completely raised before transiting underneath.
- Do not remain stationary under the beam.
- Do not stand in the vicinity of the barrier or allow anyone else, especially children, to do so and do not place objects in the vicinity of the barrier. This is particularly important during operation.
- Keep remote controls or any other control device out of the reach of children to prevent them from accidentally operating the barrier unit.
- Do not allow children to play with the barrier unit.
- Do not deliberately obstruct the movement of the beam.
- Make sure that branches or bushes do not interfere with the movement of the beam.
- Keep the luminous signalling systems efficient and clearly visible.
- Do not attempt to operate the beam manually without first unlocking it.
- In the event of a malfunction, unlock the beam to allow access and call a qualified technician for service.
- After manual operation, disconnect the electrical power supply from the system before returning to normal operation.
- Do not make any modifications to components belonging to the barrier unit system.
- Do not attempt to perform any repair work or tamper with the barrier unit. Call qualified personnel for repairs.
- At least once every six months have the barrier unit, the safety devices and the earth connection checked by a qualified technician.

DESCRIPTION

The 630 barrier unit is ideal for controlling vehicle access areas up to 4 metres wide and with medium transit frequencies.

The housing contains an extremely compact hydraulic unit and a beam balance spring.

The beam consists of a white painted aluminium bar with red reflectors to ensure good visibility even in the dark.

Barrier operation is controlled by an electronic control unit mounted in an enclosure which assures adequate protection against atmospheric agents and can be fitted inside the housing.

The normal position of the beam is closed in a horizontal position. When the electronic control unit receives an opening command from the remote radio control or any other control device, it activates the hydraulic system and causes the beam to rotate upwards by 90° to the vertical position and thereby allow access. If automatic operation has been selected, the beam closes automatically after

the selected pause time.

If semiautomatic operation has been selected, a second impulse must be sent to close the beam.

An open command given while the beam is closing causes the beam to reverse direction of movement.

A stop command (if available) stops movement at any time. For detailed information on barrier operation in the various operating modes, contact the installation technician.

The barrier units have safety devices (photocells) that prevent the beam from closing when they are darkened by an obstacle. The 630 barrier unit is fitted as standard with an anti-crushing safety device that limits the torque transmitted to the beam.

The hydraulic system ensures that the beam can be locked in any position.

The beam can then be opened manually only by using the unlocking device.

The light flashes while the beam is moving.

MANUAL OPERATION

If the barrier has to be operated manually due to a power failure or malfunction, use the unlocking device as follows.

The key provided can be triangular (standard) or personalised (optional).

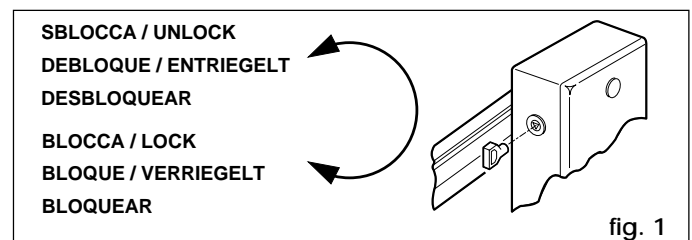

fig. 1

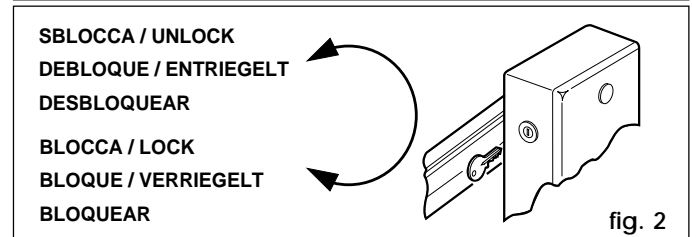

fig. 2

- Insert the standard key (fig. 1) or the personalised key (fig. 2) in the lock and **turn anticlockwise** by one revolution.
- Open or close the barrier manually.

RETURNING TO NORMAL OPERATION

To prevent an accidental impulse from activating the barrier, turn off the system's electrical power supply before returning to normal operation.

triangular key (standard):

- turn the key **clockwise** until it stops, then remove it.

personalised key (optional):

- turn the key **clockwise** until it stops.
- turn the key **anticlockwise** very slowly to the point where it can be removed.